

DIGIMIX®

MECHANICAL AGITATOR FOR **ANAEROBIC DIGESTION TANK**

- **INSIDE THE PROCESS OF SLUDGE TREATMENT**
 - **STRONGLY BUILT AND RELIABLE**
 - **GUARANTEES OPTIMUM EFFICIENCY**
 - **EASY INSTALLATION AND MAINTENANCE**

**DIGIMIX® - Vertical agitator
with axial flow**

**To homogenize sludge
and to keep it in suspension**

For tanks up to 15 000 m³



mixel
agitators

DIGIMIX®

MECHANICAL AGITATOR FOR ANAEROBIC DIGESTION TANK

- **Specific operating conditions**

Atex explosive zone, biogas gaseous roof, operating 24h/24h, 40 g/l concentrated sludge, 60 to 200 mbars pressure, 38°C temperature.

- **Strongly built and reliable components**

Atex motorization up to 22 kW.
Raising support with conical rollers bearings to guide very long agitation shafts (up to 25 meters).

- **Efficient propellers**

The geometry of Mixel TTF propellers increases the energetic efficiency of DIGIMIX.

- **An easy to use agitator**

Easy to set up on the tank thanks to the specially designed fixing flange and to the propellers blades hooking system.
Simple to keep up thanks to hydraulic sealing system, without wearing part.

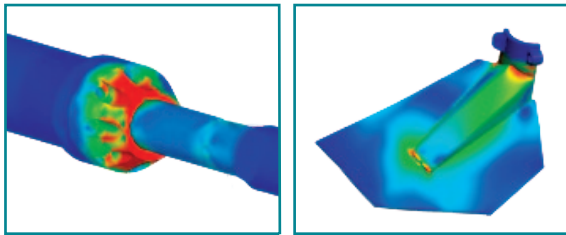

Calculation of mechanical strength

Detail of sealing system and of fixing flange

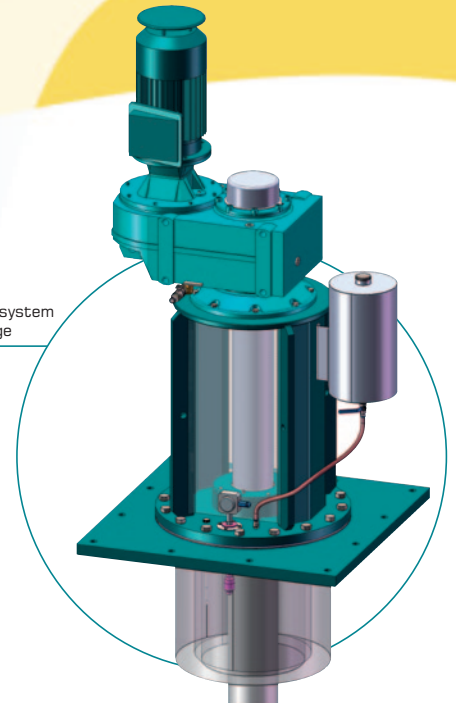

Detail of hooking system of propeller blades

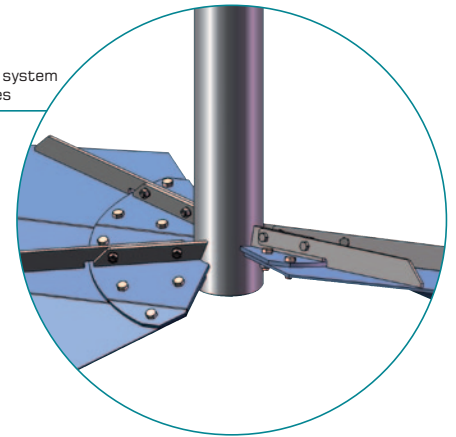

Installation for methanization of waste water plant sludge



Digestion tank (with several agitators) - Baraki - Algeria

Our references:

- **OTV** (Annaba Algeria, Khourigba Morocco, Sour Tyr Lebanon...)
- **BIWATER** (Tamuda bay Morocco...)
- **VA TECH WABAG** (Baraki Algeria...)